

TECHNICIAN TESTED

TECHNIQUES

BY

Viking Preferred Service

TECH – NOTES

BUILT- IN ELECTRIC WALL OVENS

(BEFORE JUNE 2001)

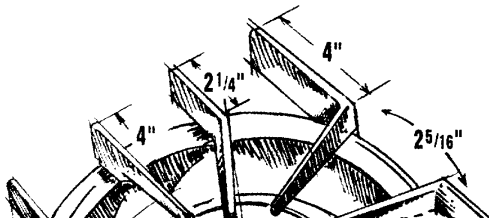

VIKING[®]
Preferred Service

**VIKING PREFERRED SERVICE
TECH – NOTES
BUILT – IN ELECTRIC WALL OVENS**

ELECTRICAL REQUIREMENTS		
Description	30" Wide Single Oven	30" Wide Double Oven
Electrical Requirements	4 – Wire ground, 240 – 208 / 120 VAC / 60 Hz, 40 amp electrical connection. Unit is equipped with No. 10 ground wire in conduit. Should be fused separately	
Maximum Amp Usage	240 – 18.9 Amps 208 – 14.2 Amps	240 – 31.8 Amps 208 – 23.9 Amps
Broil Rating	240 Volts Maxi Broil 8 Pass 3000 Watts Mini Broil 4 Pass 1250 Watts	208 Volts 2250 Watts 940 Watts
Bake Rating	240 Volts – 2935 Watts	208 Volts – 2205 Watts
Convection Cook Rating	240 Volts – 2200 Watts	208 Volts – 1650 Watts

VOLTAGE and RESISTANCE READINGS

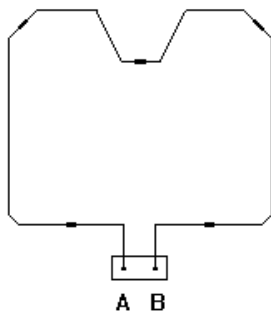

BAKE ELEMENT:

“A” to “B” 21.1 Ohms

“A” to “B” 240 Volts during Bake and Convection Bake.

CONVECTION ELEMENT

“A” to “B” 26 Ohms

“A” to “B” 240VAC during Convection Cook

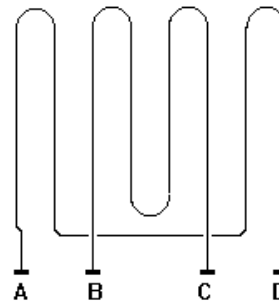
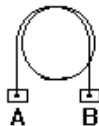

BROIL ELEMENT

“A” to “D” (Outside Element) 32.6 Ohms
50VAC during Bake and

Convection Bake
240VAC during Maxi Broil.
240VAC during Convection Broil
240VAC during Self-Clean

“B” to “C” (inside element) 45.2 Ohms

“B” to “C” 70VAC during Mini Broil /
Convection Bake

240 VAC during Mini Broil
240VAC during Maxi Broil
240VAC during Convection Broil
240VAC during Self-clean

VESO / VEDO COMPONENT ACCESS

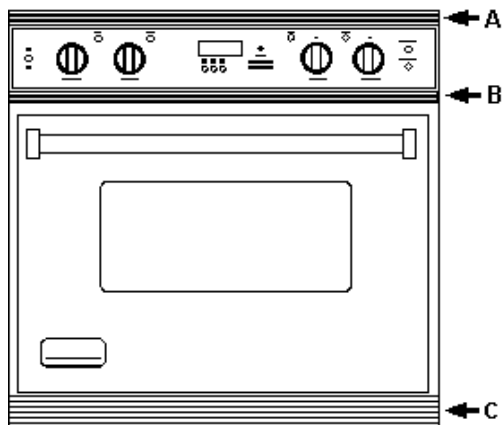
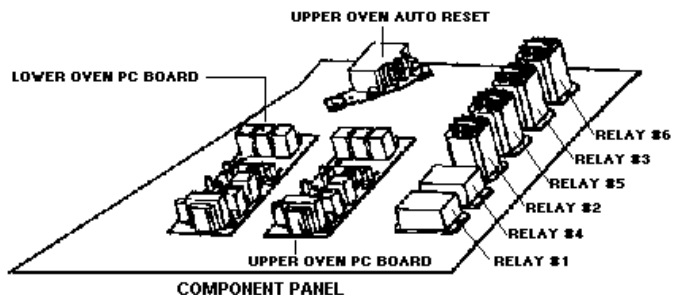
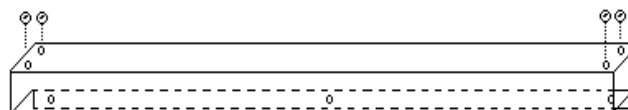

Illustration #1



TO GAIN ACCESS TO THE ELECTRIC AND ELECTRONIC COMPONENTS:

Remove the **Top Trim (A)**. Two screws at each corner attaching the top trim to the side trims and three screws along the bottom of the trim piece.
 Remove the **Lower Control Panel Trim (B)**. Three Screws along the bottom of the trim piece behind the oven door.

Remove the **Control Panel**. Four screws at the top and six screws across the bottom (see drawing of the control panel.) Pull the **Control Panel** carefully forward and tilt down. Being careful not to disconnect wires attached to the components on the reverse of the panel.

The **Component Panel** is now accessible. Pull the **Component Panel** forward to release the panel from the slide. Lift the **Component Panel** up to service the upper **Upper Self Cleaning Latch** and components located on the latch mechanism.

The **Bottom Trim (C)** is removed to make the vertical **Door Adjustment**. Remove the two screws from each corner attaching the **Bottom Trim** to the **Side Trim** pieces. Remove the three screws across the top of the trim piece located beneath the door.

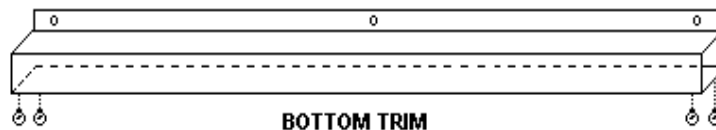
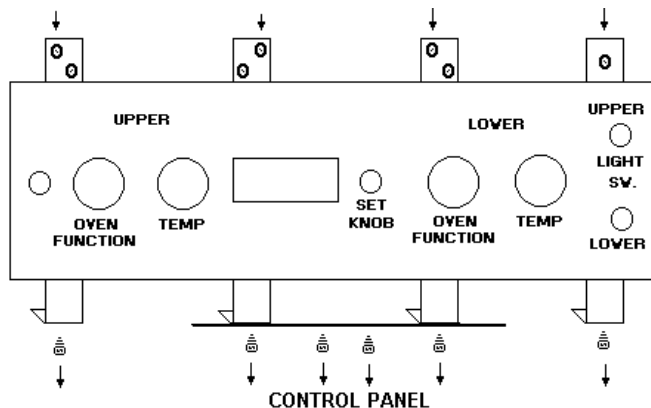

VGSO105 SINGLE SELF-CLEAN WALL OVEN
 Relay location and wiring connections

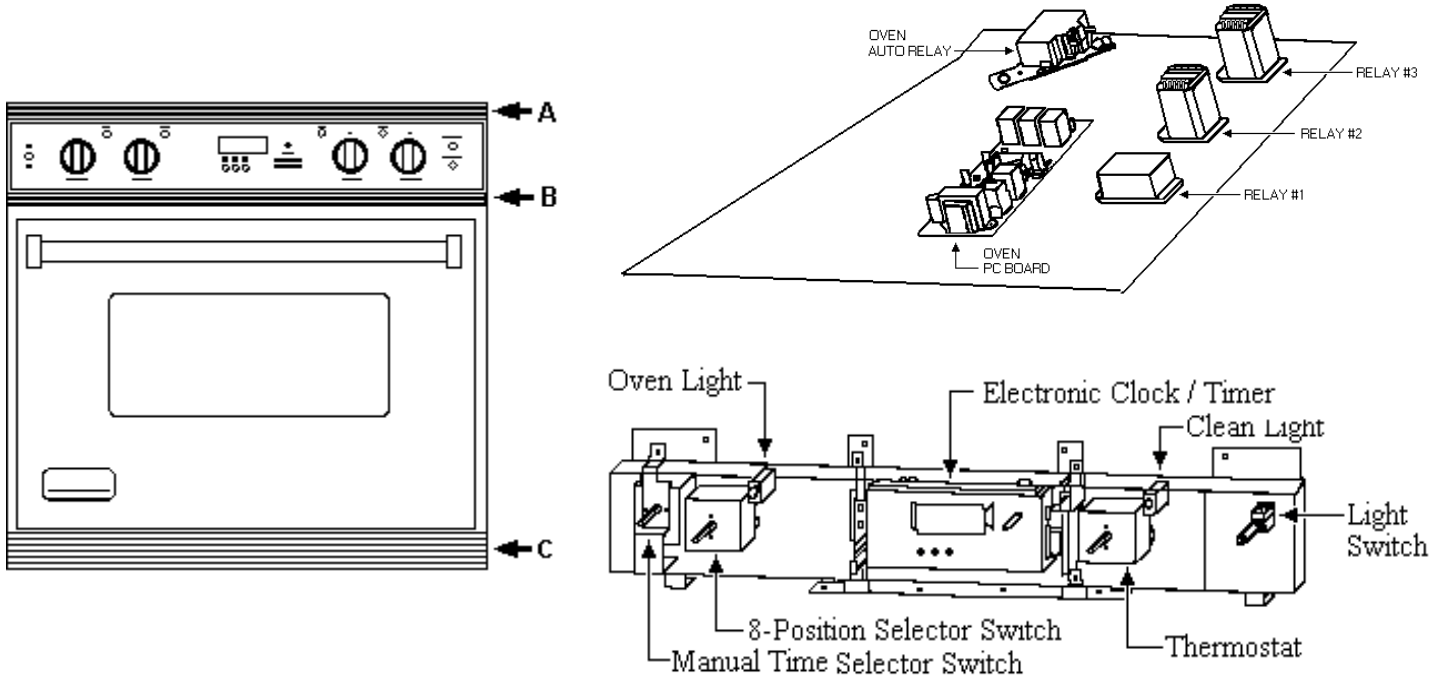

VESO 105 / VEDO 205 TOP OVEN

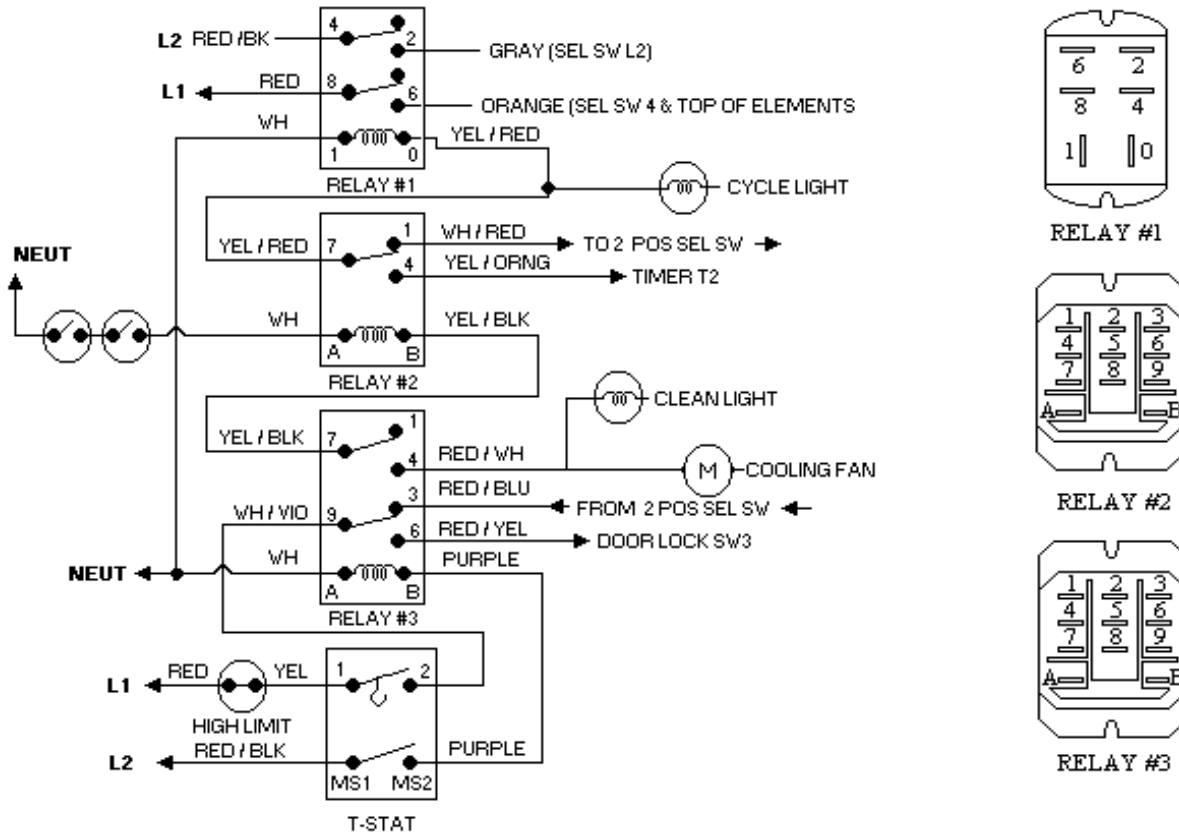

VIKING PREFERRED SERVICE
 TECH -- NOTES

VEDO DOUBLE SELF-CLEAN WALL OVEN
 Relay location and wiring connections

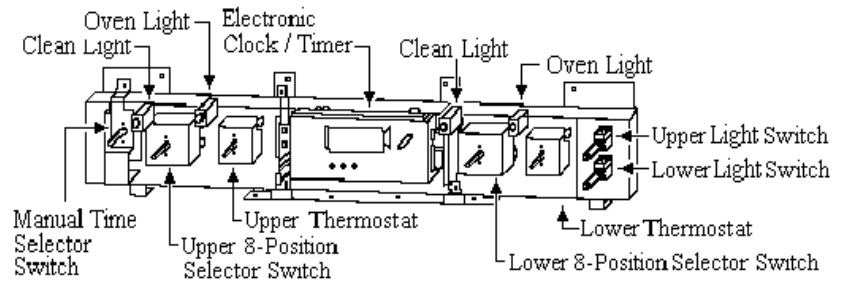
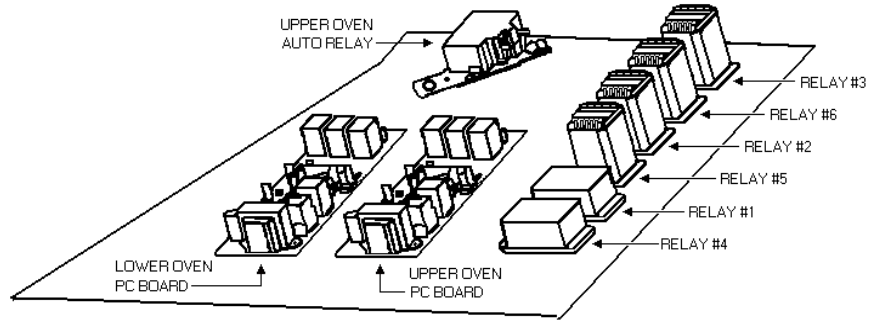
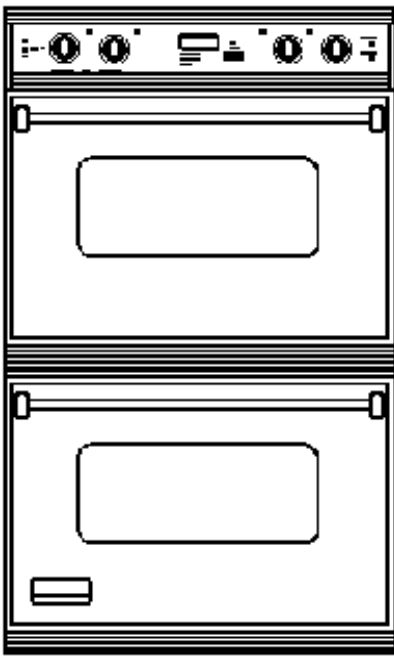

VEDO 105 / VEDO 205 TOP OVEN

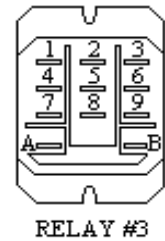
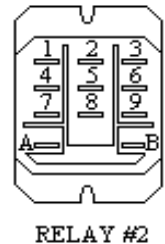
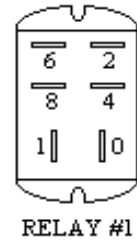
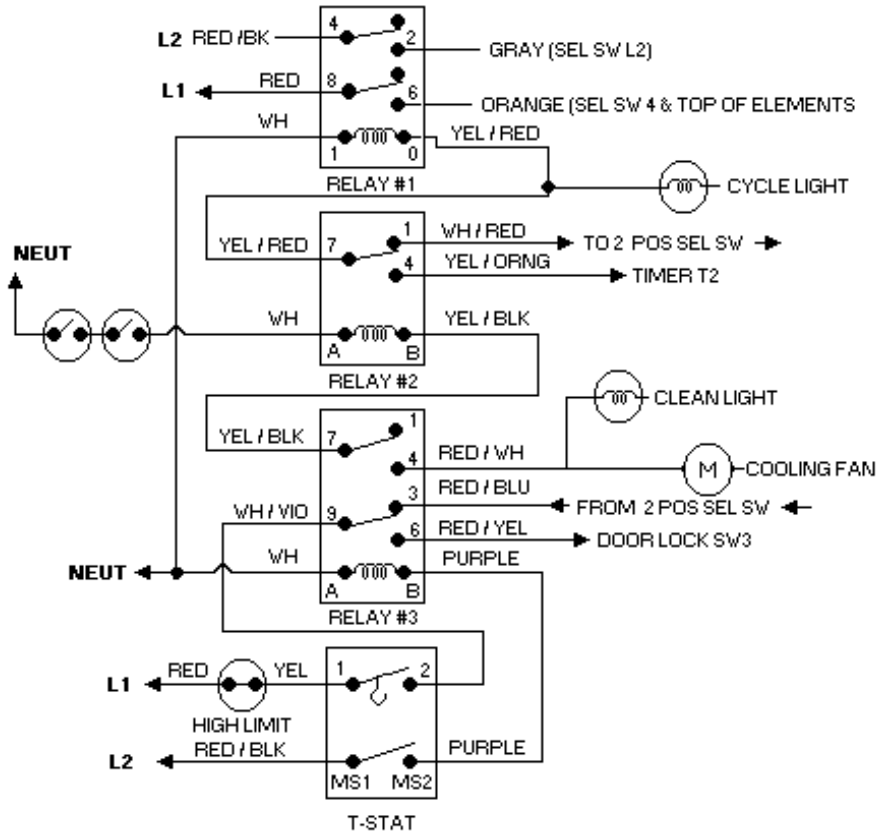

VEDO DOUBLE SELF-CLEAN WALL OVEN
 Relay location and wiring connections

VEDO 205 BOTTOM OVEN

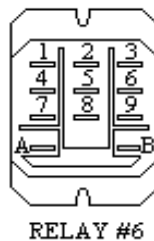
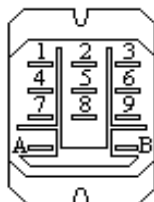
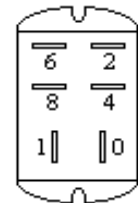
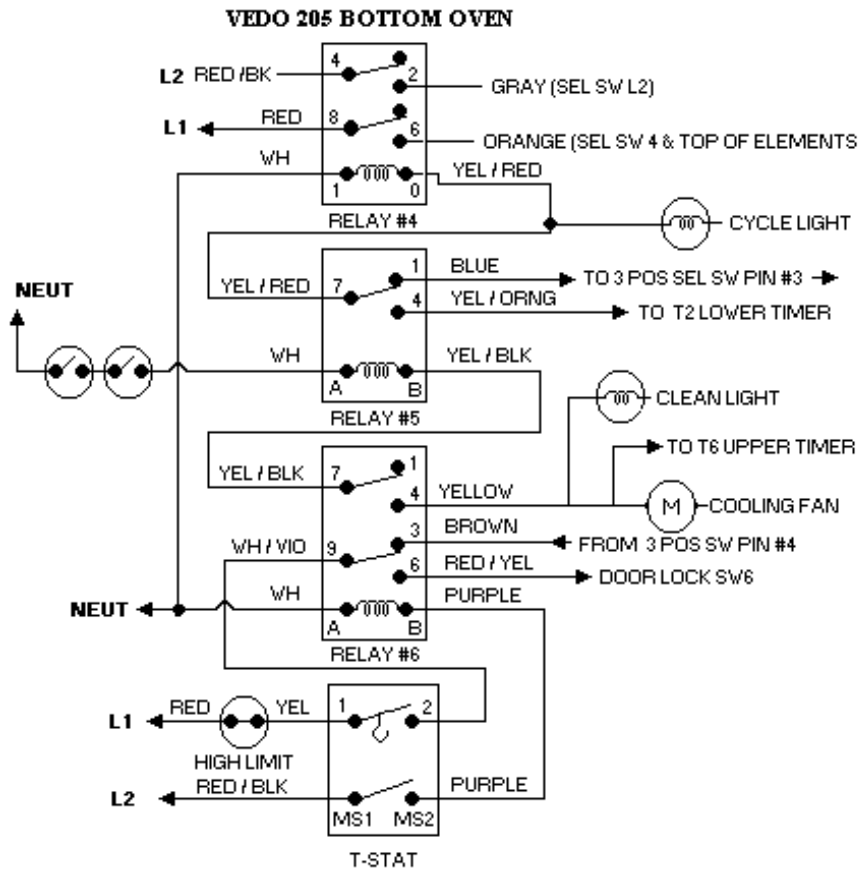

8 Position Selector Switch

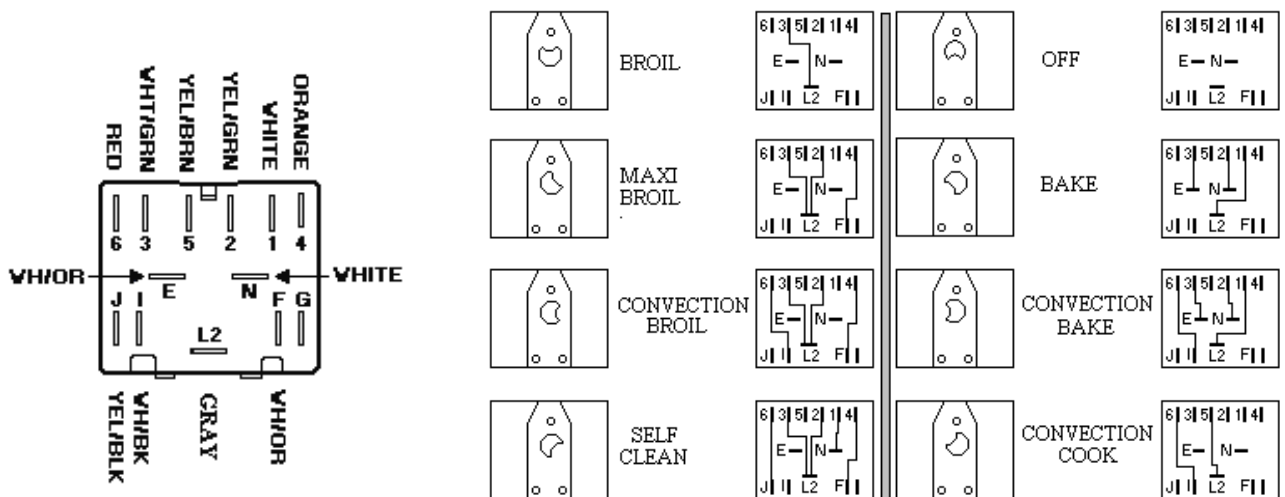

DOOR LOCK CONTROL / TIMER

Function: The Door Lock Control / Timer is activated by the line voltage at the “SEL” contact.

Voltage Readings: Measured with Door Open.

T4	120VAC	
T3	0VAC	
T2	0VAC	
T1	0VAC	

Voltage: Measured with Door locked.

T4	120VAC
T3	120VAC
T2	120VAC

VC -- 4VDC to

- Sensor 3 -- 3VDC SW2 closed in self-clean (locked)
- Sensor 4 -- 4VDC SW1 closed with self-clean (unlocked)
- M1 -- 120VAC lock motor supply voltage (0VAC in locked position.)
- LS2 -- 120VAC (unlocked) -- 0VAC (locked)
- L1 -- 120VAC (unlocked) -- 0VAC (locked)
- L2/M2 -- 120VAC (unlocked) -- 0VAC (locked)
- LS1 -- 120VAC -- 0VAC locked
- SEL -- 120VAC supply

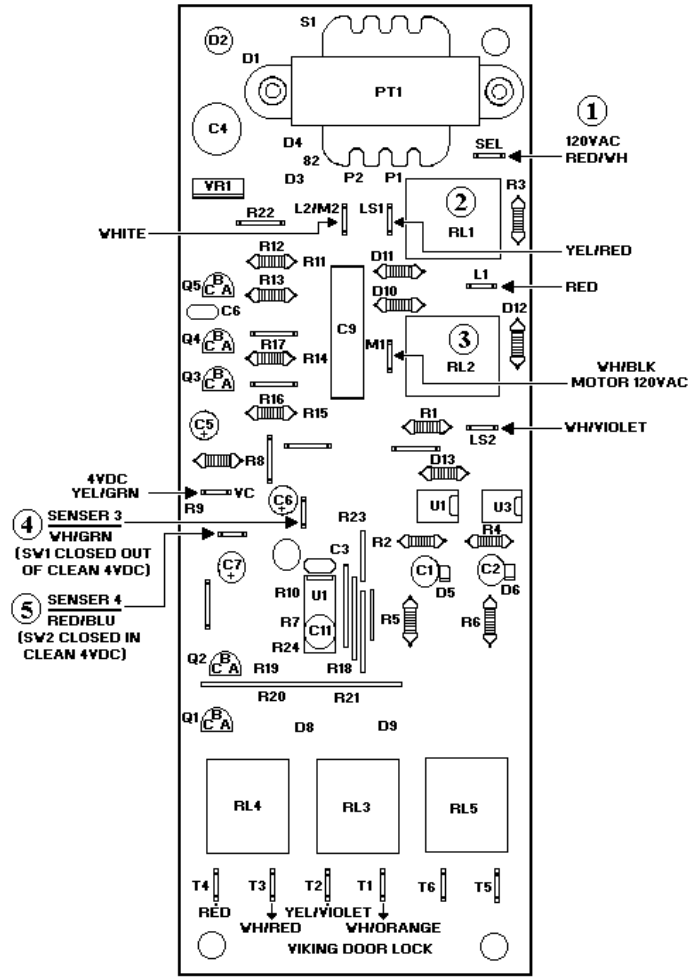

CONTROL CIRCUIT BOARD

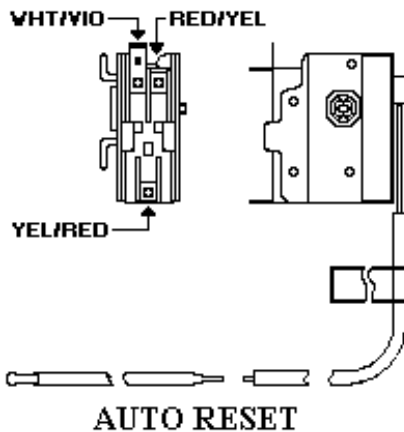

AUTO RESET SWITCH

Function: The Auto Reset Switch is a single pole double throw switch (thermostat) which is activated by a thermal bulb and lever which is calibrated to **575° F ± 25° F**. The Auto Reset Switch powers the door lock motor to lock at temperatures at or above **575° F**. Also allows the door to unlock after the temperature drops below **575° F**.

VIKING PREFERRED SERVICE
 ————TECH -- NOTES————

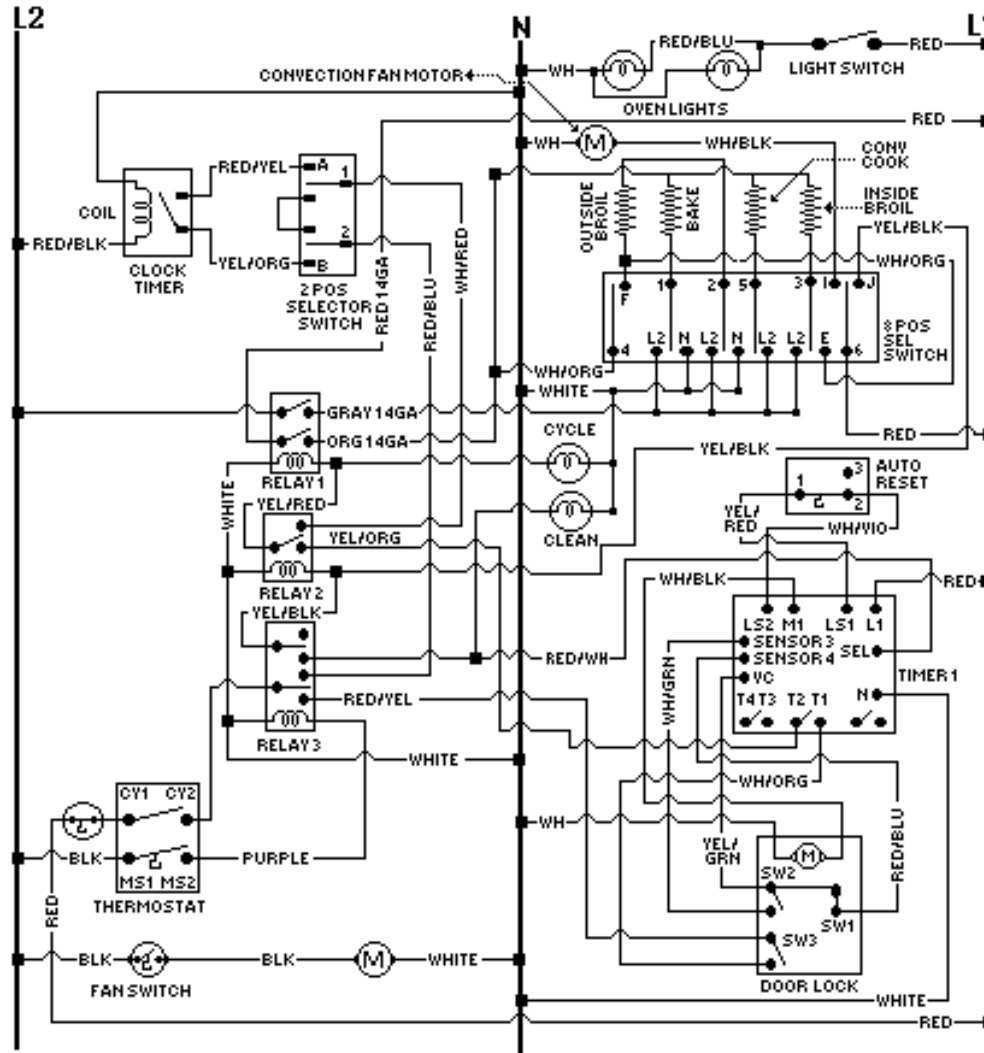

VIKING PREFERRED SERVICE

TECH -- NOTES

BUILT-IN ELECTRIC DOUBLE OVEN

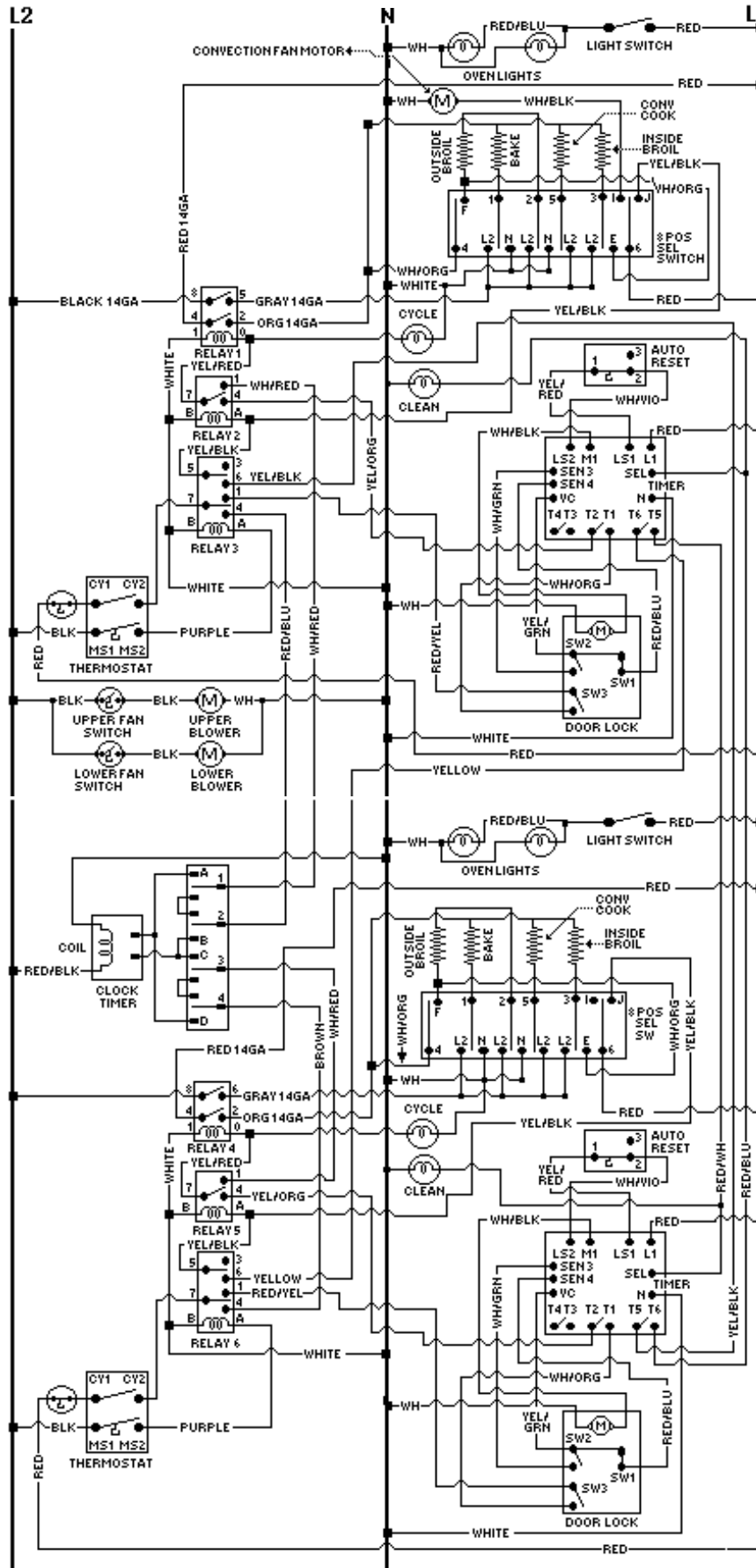

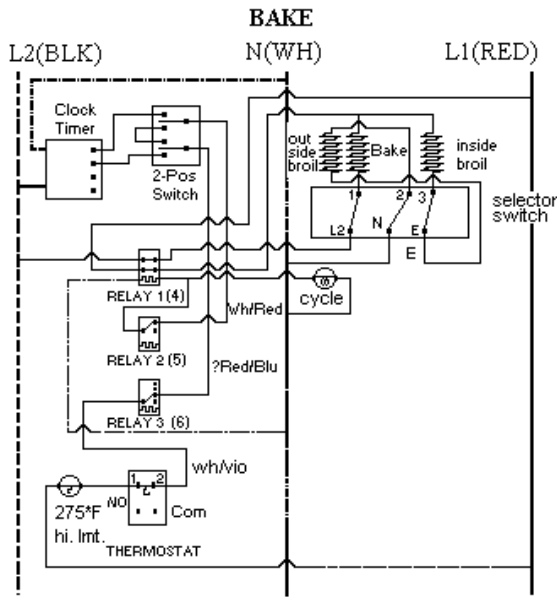

SELECT BAKE position closes switches 1-L2, 2-N, and 3-E. The thermostat closes switches Cy1-Cy2, which cycles with oven temperature powering relay 1 and the oven cycle light. When relay 1 closes, it powers the bake element at 208/240 VAC, and with the broil element in series across a 120VAC circuit, it powers the inside broil element at 70VAC and the outside broil element at 50VAC.

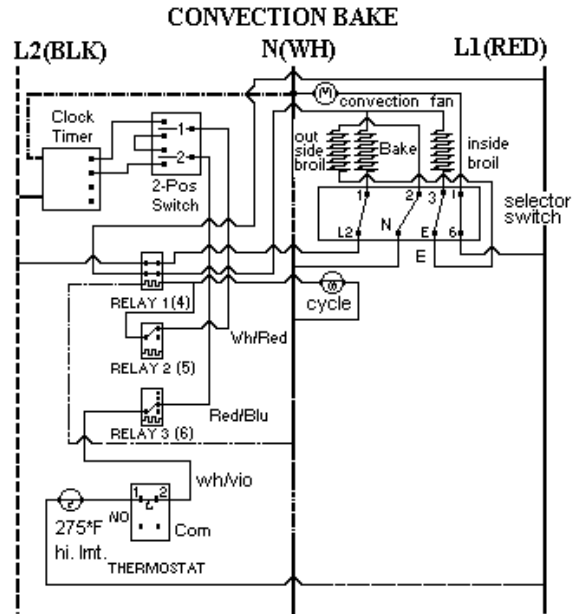

SELECT CONVECTION BAKE position closes switches 1-L2, 2-N, 3-E, and 6-1. 6-1 powers the convection fan through L1 at 120VAC. The thermostat closes switch Cy1-Cy2, which cycles with oven temperature powering relay 1 and the oven light. When relay 1 closes, it powers the bake element at 208/240VAC, and with the broil element in series across a 120VAC circuit, it powers the inside broil element at 70VAC and the outside broil element at 50VAC.

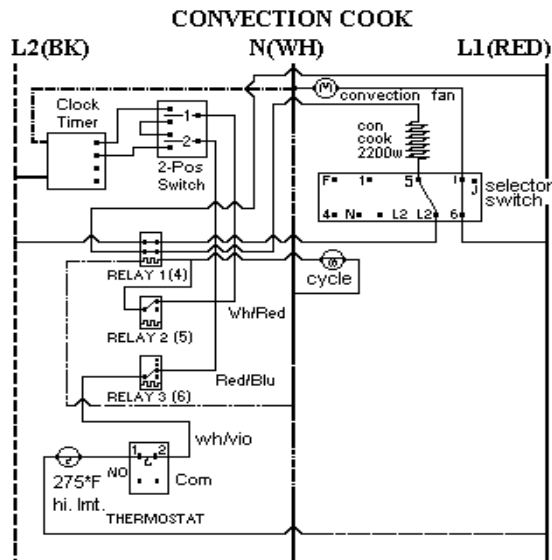

SELECT CONVECTION COOK position closes switches 5-L2 and 6-1. 6-1 powers the convection fan through L1 at 120VAC. The thermostat closes switches Cy1 - Cy2, which cycles with oven temperature, powering relay 1 and the oven light. When relay 1 closes, it powers the convection element at 208/240VAC.

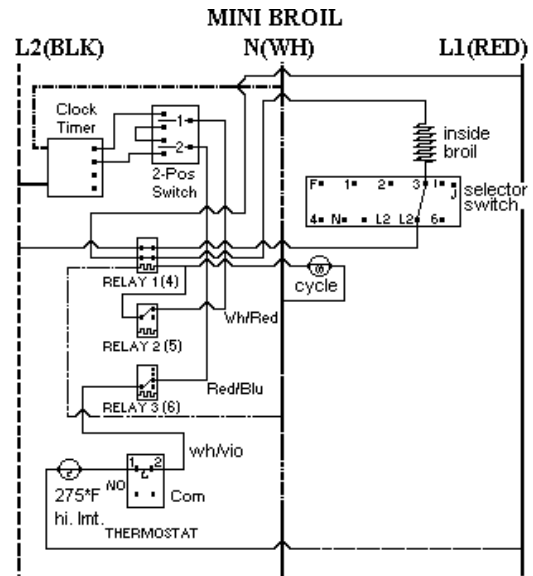

SELECT MINI BROIL position closes switches 3-L2. The thermostat closes switch Cy1-Cy2, powering relay 1 and the oven cycle light. When relay 1 closes, it powers the inside broil element at 208/240VAC.

VIKING PREFERRED SERVICE

TECH -- NOTES

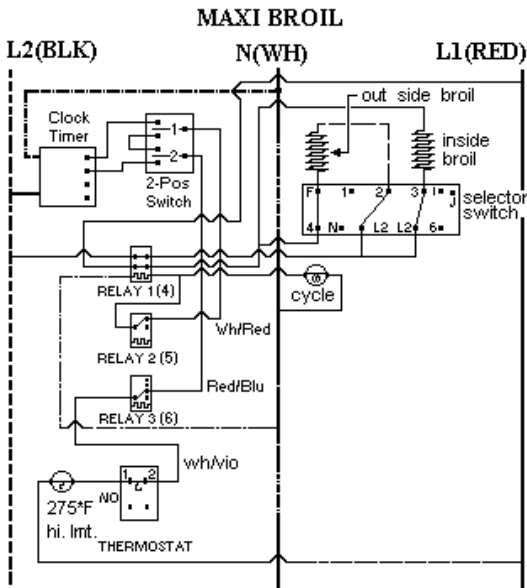

SELECT MAXI-BROIL position closes switches 4-F, 2-L2, and 3-L2. The thermostat closes switch Cy1-Cy2, which cycles with oven temperature, powering relay 1 and the oven cycle light.. when relay 1 closes, it powers the inside broil element at 208/240VAC and the outside broil element at 208/240VAC.

CLEAN INITIATE UNTIL DOOR LOCK

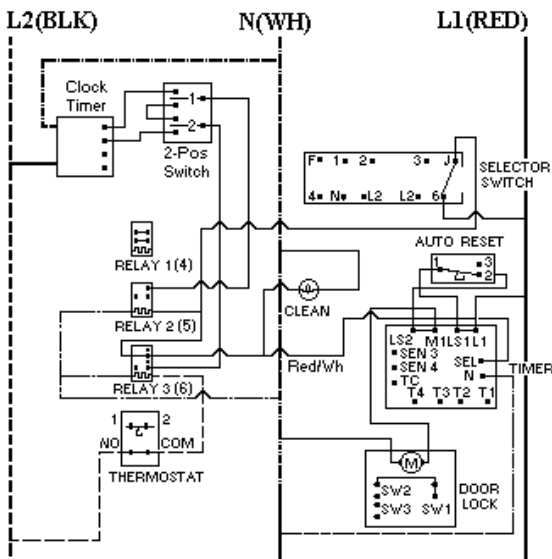

SELECT CLEAN position closes heating element circuits 4-F, 1-N, 2-L2, 3-L2 and door lock module / timer circuit J6 switches relay2. Thermostat clean position closes the cycle switch and thermostat clean switch, which switches relay 3. Switching relay 3 allows circuit J-6 to turn on the clean indicator light and enable the door lock module / timer which closes relay LS-L1 and LS2-M1. This powers the door lock motor until 10 seconds after sensor #3 is signaled by VC that the door lock switch SW2 has been closed mechanically (along with SW3) by the door lock bolt.

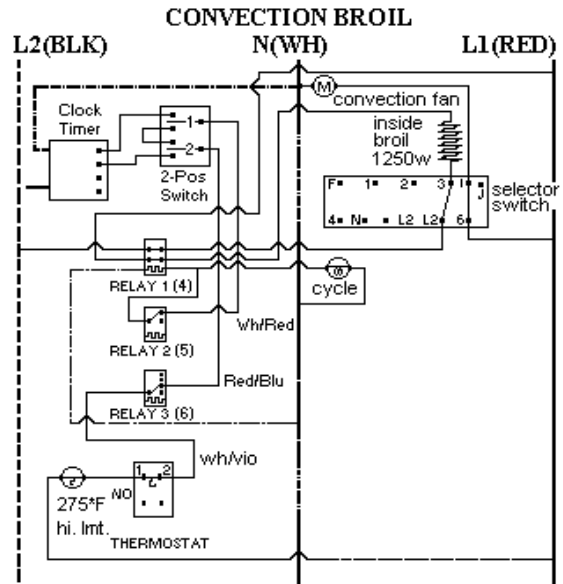

SELECT CONVECTION BROIL position closes switches 4 - F, 2 -L2, 3 - L2 and 6 - 1. 6 -1 powers the convection fan through L1 at 120VAC. The thermostat closes switch Cy1 - Cy2, which cycles the oven temperature, powering relay 1 and the oven cycle light. When relay 2 closes it powers the inside broil element at 208/240VAC and the outside broil element at 208/240VAC.

CLEAN DOOR LOCK BELOW 575° F ± 25° F

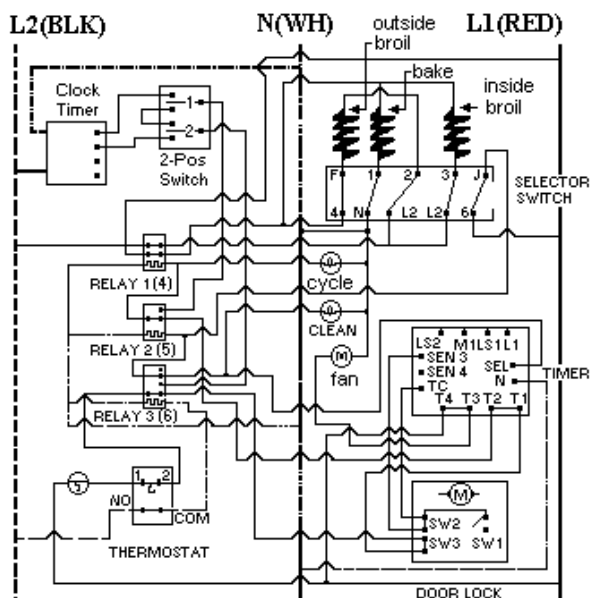

10 seconds after the signal to sensor #3, switch LS2 - M1 is opened, stopping the door lock motion and switches T1 - T2 and T3 - T4 which switches relay 1, powering the cooling fan, which closes relay 1 powering the inside and outside broil elements at 208/240VAC and the bake element to 120VAC.

VIKING PREFERRED SERVICE
 ———— TECH -- NOTES ————

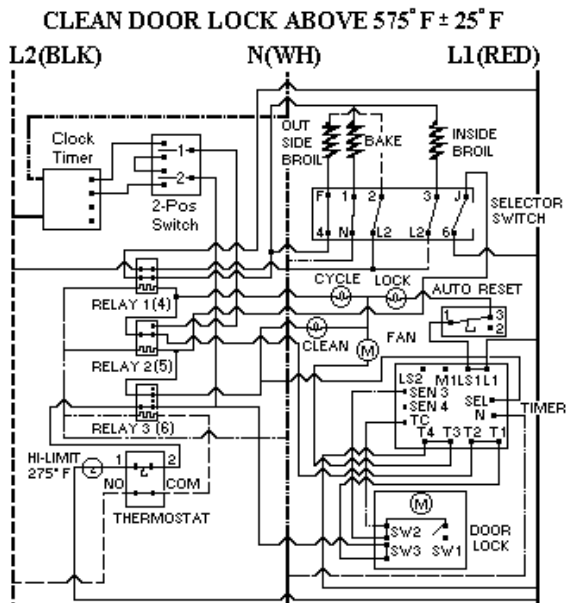

AUTO RESET switches to 1 – 3 which turns door lock indicator light on and disables door lock motor circuit.

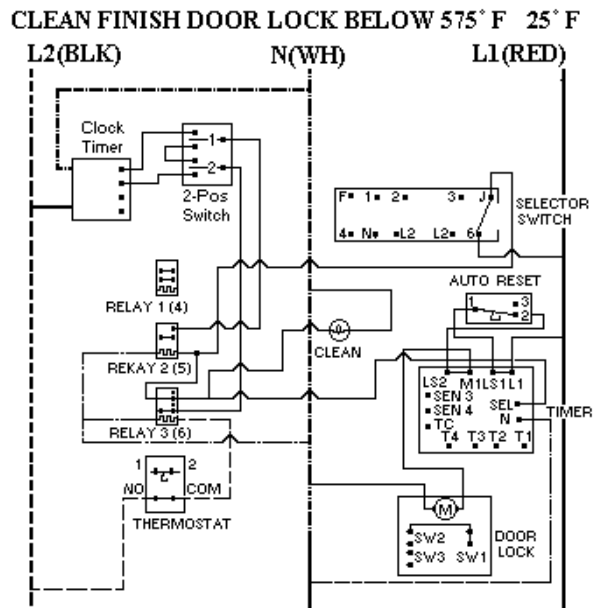

AUTO reset switches 1 – 2 closed allowing the door lock motor to operate and turning the door lock light off. The door lock motor operates until 2 seconds after sensor 4 is signaled by VC that the door lock SW1 has been closed mechanically by the door lock bolt. The door lock / timer switches LS2 – M1 and LS1 – L1 open and the timer resets.

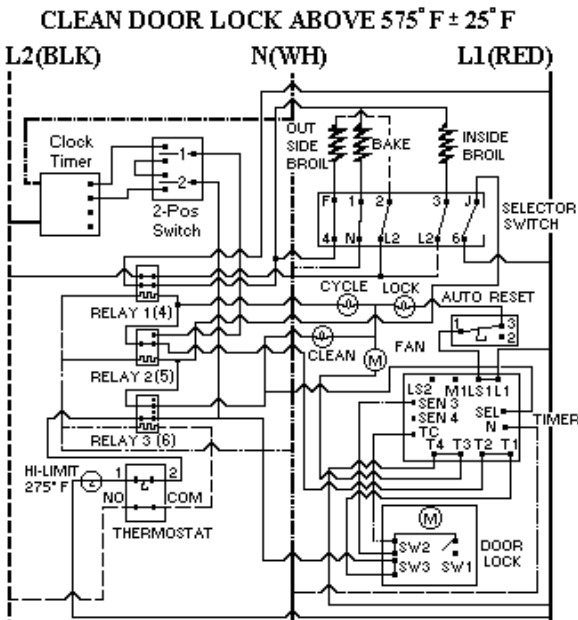

TIMER switches T3 – T4, T1 – T2 open, turning off the cooling fan, which will then be powered at 120VAC by the fan limit switch when needed, and opening the circuit to relay 1 which disables the heating elements. Switch LS2 - M1 closes to power the door lock Motor.

VIKING PREFERRED SERVICE

———TECH -- NOTES———

TROUBLESHOOTING GUIDE Electric Wall Ovens

PROBLEM	PROBABLE CAUSE	CORRECTION
A. No Bake, No Broil No Cycle Light, No Power to Relay #1	A-1 House Breaker or Fuse open	A-1 Reset Breaker or replace Fuse
B. No Bake, No Broil, No Cycle Light, Power to Relay #1 (Red – Red/Blk terminals #1 & #3) No power to Relay #1 Heater	B-1 Timed Bake/Broil function switch set to Timed function. B-2 Power Relay #1 Heater circuit open . B-3 Open contacts Relay #2 (single/ upper oven) (wh/red wire to neutral pin #1 and #7) B-4 Open contacts Relay #3 (single/upper oven) (red/blu contact #3 to wh/vio contact #9) or open contact Relay #6 (lower oven) (Brown contact #3 to wh/vio contact #9) B-5 Open Thermostat Cycling contacts #1 and #2 B-6 Open High Limit Switch (contacts normally Closed)	B-1 Set Timed Bake/Broil function switch to manual. B-2 Replace Power Relay #1 (Power Relay #1 part # PM010026) B-3 Replace Relay #2 (single/ upper oven) or #5 (lower oven) (Relay #2 and #5 part # PM010029) B-4 Replace Relay #3 (upper oven) or Relay #9 (lower oven) (Relay part # PM010029) B-5 Replace Thermostat B-6 Replace High Limit Switch
C. No Bake Function Broil functions normal and the Cycle Light is on	C-1 Open Bake Element C-2 Open Selector Switch contacts 1 to L2 C-3 Burned Wiring or Terminal connections.	C-1 Replace Bake Element C-2 Replace Selector Switch C-3 Replace or Repair Burned Wiring and / or Terminal (spade) connector.
D. Poor Baking Results, Broil Functions normal Cycle Light is on	D-1 Low Voltage Supply (240VAC Required). D-2 Restricted Air Flow through the oven cavity. D-3 No Top Heat from Broil Element. Open selector Switch contacts 3 to E. D-4 Check Use and Care for suggested baking tips.	D-1 Inform Customer of requirements. D-2 Clear restriction from Oven Vent. D-3 Replace Selector Switch.
E. No Convection Bake, Bake and Broil functions normal, Cycle Light is on.	E-1 Open Selector Switch contact 6 to 1 E-2 Open Convection Motor winding E-3 Burned Wiring or terminal connections	E-1 Replace Selector Switch E-2 Replace Convection Motor Replace burned wiring or terminal connectors.
F. No Convection Cook, Bake and Broil functions normal. Cycle Light is on.	F-1 Open Convection Cook Element F-2 Open Selector Switch contacts 5 to L2	F-1 Replace Convection Cook Element. F-2 Replace Selector Switch

VIKING PREFERRED SERVICE
 ————TECH -- NOTES————

TROUBLESHOOTING GUIDE Electric Wall Ovens		
PROBLEM	PROBABLE CAUSE	CORRECTION
G. Convection Cook Heats, No Air Circulation	G-1 Open Winding in Convection Fan Motor G-2 Frozen Motor Shaft G-3 Open Selector Switch contacts 1 to 6	E-1 Replace Fan Motor E-2 Replace Fan Motor E-3 Replace Selector Switch
H. No Mini-Broil, Bake functions normal, Cycle Light is on.	H-1 Open Selector Switch contacts 3 to L2 H-2 Open Inside Broil Element	H-1 Replace Selector Switch H-2 Replace Inside Broil Element
I. No Maxi-Broil, Bake and Mini-Broil functions normal, Cycle Light is on.	I-1 Open Selector Switch contacts F to 4, 2 to L2 and / or 3 to L2 I-2 Open Outside Broil Element	I-1 Replace Outside Broil Element
J. No Maxi-Broil, No Top heat in Bake Mode, Cycle Light is on.	J-1 Open Selector Switch contacts F to 4, 2 to L2 J-2 Open Inside and Outside Broil Elements.	J-1 Replace Selector Switch J-2 Replace Open Broil Elements.
K. No Convection Broil Bake and Broil are Normal, Cycle Light Is on. No Mini-Broil	K-1 Open Convection Motor winding K-2 Open Selector Switch contacts 3 to L2 K-3 Open Inside Broil Element	K-1 Replace Convection Motor. K-2 Replace Selector Switch K-3 Replace Inside Broil Element
L. No Self-Clean, Bake and Broil functions normal <ul style="list-style-type: none"> ▪ Door won't lock. No Clean Light. No 120 VAC supply to Door Lock module / timer (PC board) 	L-1 Open Selector Switch contacts J to 6 L-2 Open contacts Relay #2 (single/upper oven) or Relay #5 (lower oven). L-3 Open contacts Relay #3 (single/upper Oven) or Relay #6 (lower oven).	L-1 Replace Selector Switch L-2 Replace Relay #2 (single/upper oven) or #5 (lower oven). L-3 Replace Relay #3 (single/upper oven) or #6 (lower oven).
M. No Self-Clean Bake And Broil function Normal. <ul style="list-style-type: none"> ▪ Door won't Lock 120VAC to Door Lock module / timer (PC board) is present – No Motor movement – Clean Light is on. 	M-1 Open Relay contacts LS1-1 and /or LS2-M1 on Door Lock Module / timer (PC board) M-2 Open contacts 1 to 2 on Auto Reset Thermostat. M-3 Open windings in Lock Motor	M-1 Replace Door Lock Module / Timer (PC board) M-2 Replace Auto Reset Thermostat M-3 Replace Lock Motor assembly

--

VIKING PREFERRED SERVICE
 ————TECH -- NOTES———

TROUBLESHOOTING GUIDE Electric Wall Ovens		
PROBLEM	PROBABLE CAUSE	CORRECTION
N. Door Lock Motor continues to run no signal to sensor #3 on PC board the closes T1-T2 and T3-T4. Clean Light is on.	N-1 No SW2 Switch (closed be motor Movement) on Door Lock Mechanism not closing.	N-1 Adjust SW2 Switch position or Replace faulty Switch.
O. Door Lock Motor Engaged. Signal To Sensor #3 on PC board . No Heat, Clean Light is on.	O-1 Door Lock Module / Timer Relay T1 –T2 and T3-T4 not closing.	O-1 Replace PC board.
P. Door Lock Motor Engaged. Cooling Fan Motor runs. (PC board T3 –T4 closing) No Heat.	P-1 Door Lock Module / Timer (PC board) Relay T1-T2 not closing. P-2 Door Lock Module / Timer (PC board) Relay T1-T2 closing. Check SW3 on Door Lock Assembly.	P-1 Replace PC board P-2 Replace SW3 switch on Door Lock Assembly .

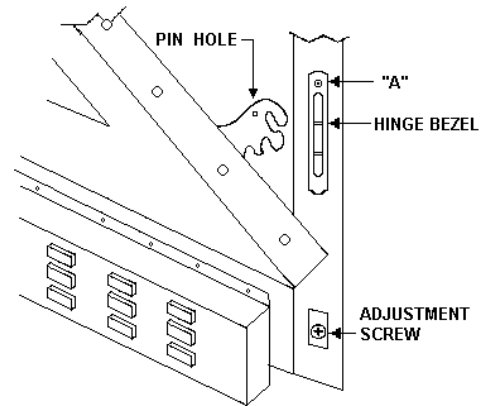
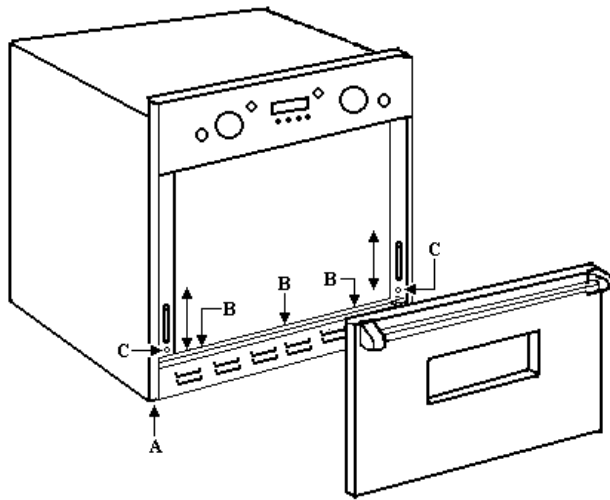

DOOR REMOVAL

- Open door to full open position
- Place a pin in the pin hole
- Close the door to the inserted pin
- Remove screw "A"
- Lift the door and hinge bezel out of the door socket
- Reverse the procedure to replace the door

DOOR ADJUSTMENT

- Remove the lower access panel
- Remove 2 screws at the bottom of each side trim (A)
- Remove the 3 screws beneath the door (B)
- (C) is the door adjustment screws (Turn Clockwise to raise the door) and (Counterclockwise to lower door)

Filename: TechW14.doc
Directory: D:\VBCODE\IPLUTILS\PDFGenerator\InputData\F90579 TechWall-01
Template: C:\Documents and Settings\tomw.EYECOM\Application Data\Microsoft\Templates\Normal.dot
Title: TROUBLESHOOTING GUIDE Electric Wall Ovens
Subject:
Author: Viking Range Corporation
Keywords:
Comments:
Creation Date: 10/13/2000 6:52 PM
Change Number: 3
Last Saved On: 3/28/2003 4:38 PM
Last Saved By: Ken Sievert
Total Editing Time: 0 Minutes
Last Printed On: 3/28/2003 7:35 PM
As of Last Complete Printing
Number of Pages: 1
Number of Words: 141 (approx.)
Number of Characters: 804 (approx.)